

SPEECON 7300PA

FAN & PUMP INVERTER



5 ~ 500 HP
4 ~ 375 KW

SPEECON 7300PA

◆ KEY FEATURES FOR HVAC APPLICATIONS

- PID & Auto Energy Saving function.
- Input Phase Loss & Output Phase Loss Protection.
- LCD keypad used as Copy Unit (Big size LED keypad Optional)
- Output common mode choke built-in.
- PF , KW, KWHr, Motor Elapsed Run Hour.
- Multi-Function Input/output interface.
- RS-485 communication – MODBUS(PA-M) METASYS N2(In plan)
 PROFIBUS(PA-P) DEVICENET(PA-D)(In plan)
- 1-8 PID card (PA-PID).
- PID Sleep/Wake-up Functions.
- 3 Analog Inputs (0-10V X 2, 4-20mA option)
- 2 Analog Outputs (0-10V X 2, 4-20mA)
- Motor Thermistor Input.
- Cooling Fan on/off control
- Completed Range : 220V 3ø 5HP ~ 125 HP 440V 3ø 5HP ~ 500 HP
- CE, UL

◆ MODEL DESIGNATION

JNTFBG BA 0025 AZ ---

Inverter Series
7300PA

Enclosure & Mounting
BA : Open chassis type (IEC IP00)
BB : Enclosed, wall-mounted type (NEMA-1)

Voltage
JK : 220V/60Hz (200V/50Hz)
AZ : 440V/60Hz (380V/50Hz)

Applicable maximum
motor output (HP)

{	0005 : 5HP	}
	0500 : 500HP	

Reserved

SPEECON 7300PA

PID FUNCTION

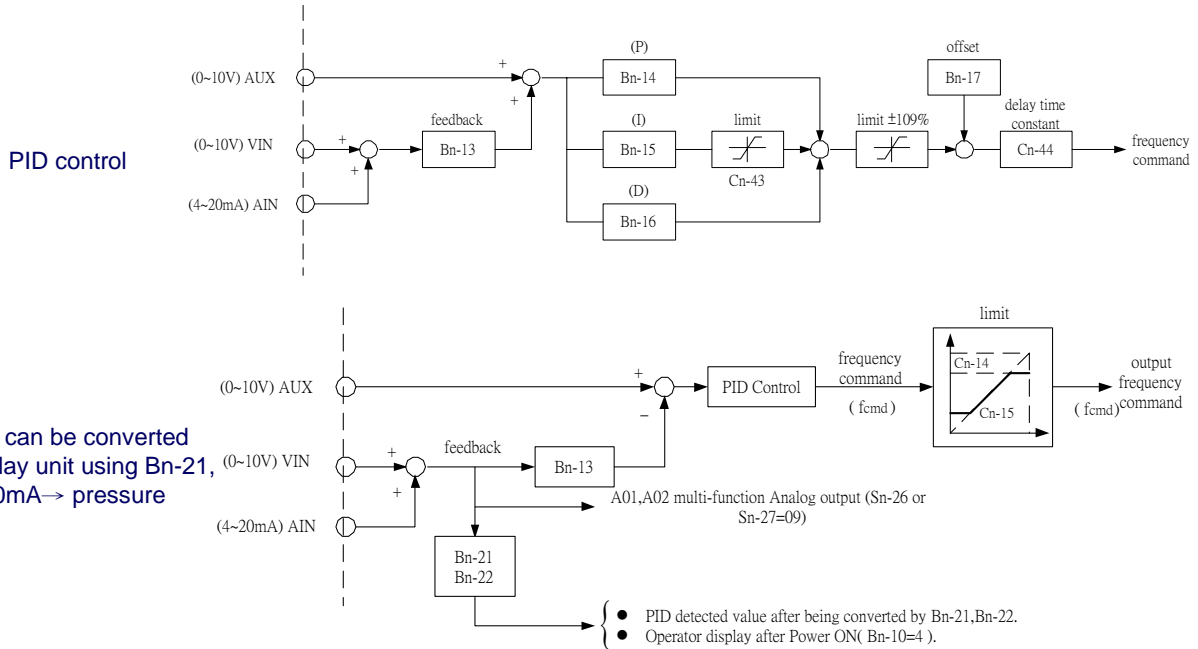

PID SLEEP/WAKE-UP FUNCTION

Sleep mode makes it possible to stop the motor when it is running at low speed and this has almost no load. If consumption in the system goes back up, the inverter will start the motor and supply the power supply. Energy saving can be saved with this function, since the motor is only in operative when the system needs it.

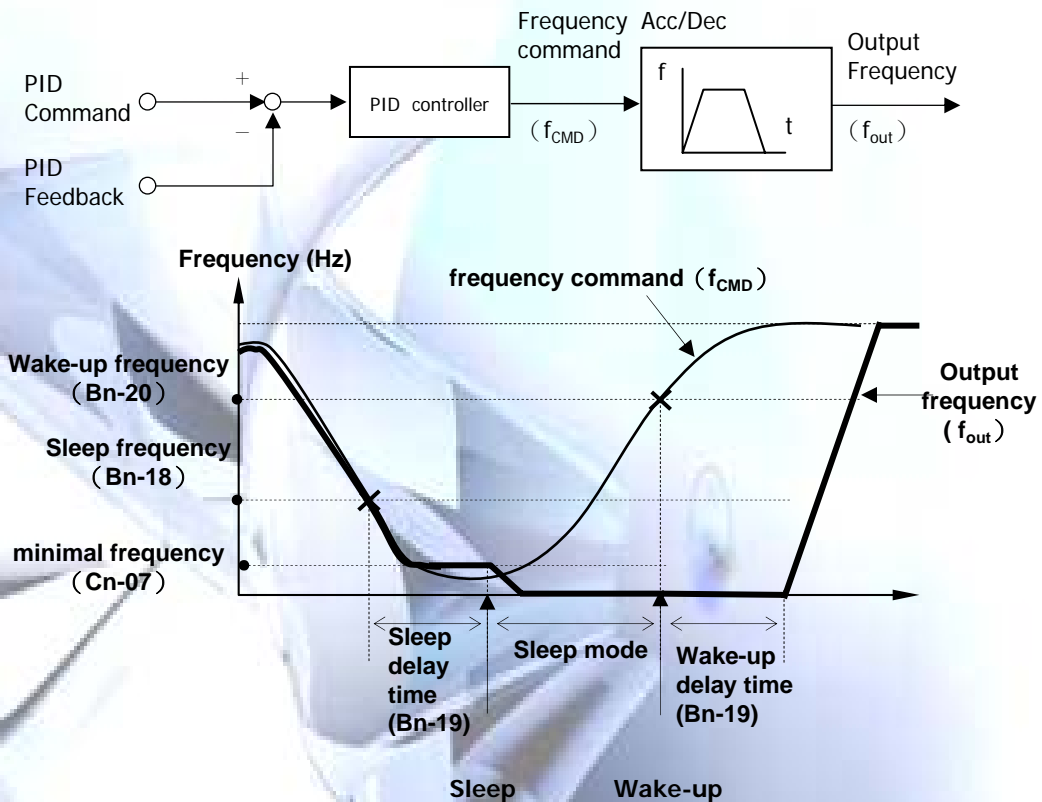

SPEECON 7300PA

1 to 8 PID OPERATION CARD

- 1 to 8 PID Card (PA-PID) with 8 relay contact output, can be used to control max 7 pumps with PID function in a constant pressure water supply system.
- The Relay constants as below:
 - Bn-23 : Frequency command upper-bound delay time
 - Bn-24 : Frequency command lower-bound delay time
 - Bn-25 : MC ON/OFF delay time
 - Bn-26 : pump ON/OFF detection level
 - Sn-30 : Pump operation mode selection
 - Sn-31 : PA-PID Card Relay2 valid/invalid
 - Sn-32 : PA-PID Card Relay3 valid/invalid
 - Sn-33 : PA-PID Card Relay4 valid/invalid
 - Sn-34 : PA-PID Card Relay5 valid/invalid
 - Sn-35 : PA-PID Card Relay6 valid/invalid
 - Sn-36 : PA-PID Card Relay7 valid/invalid
 - Sn-37 : PA-PID Card Relay8 valid/invalid
- Fixed inverter driving mode and Cycled inverter driving mode connection examples:

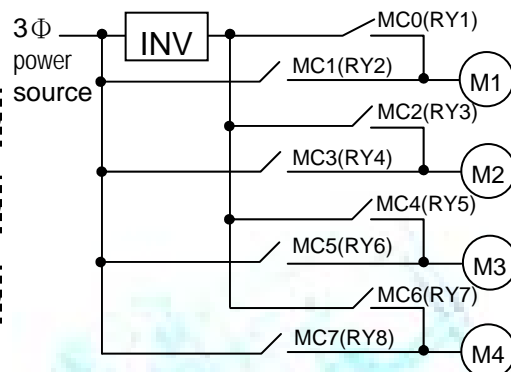
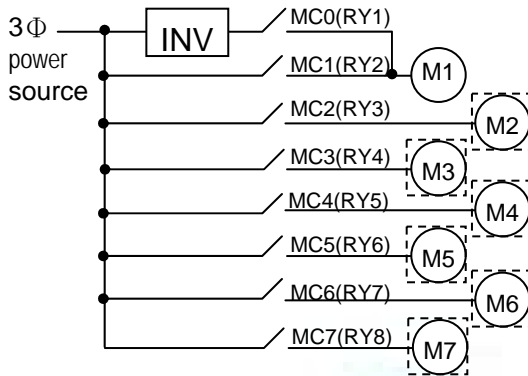

IPL-INPUT PHASE LOSS PROTECTION

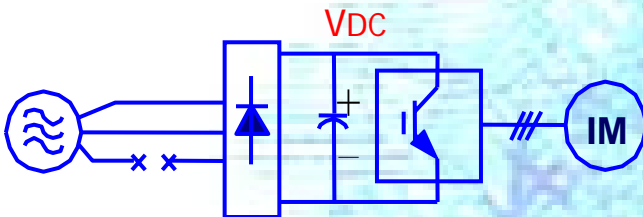

IPL function is disabled in the following cases

- Stop running
- Decelerating
- Output Current $\leq 30\% \times$ INV rated current
- IPL level $\Delta V = 100\%$
- IPL protection function is disable (Sn-28=1)
- When "A/D Fault CPF05"

OPL-OUTPUT PHASE LOSS

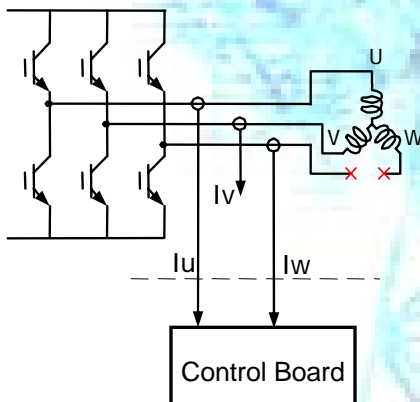

OPL function is disabled in the following cases

- Stop running
- DCDB
- Output current $\leq 30\% \times$ INV rated current
- OPL protection function is disable (Sn-13=xx1x)
- When "A/D Fault CPF05"

SPEECON 7300PA

AES-AUTO ENERGY SAVING

7300PA will auto adjustable voltage to minimize output current for different load.

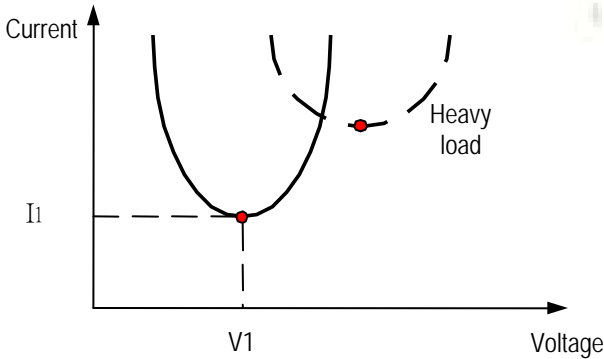

For fans, pumps and HVAC application, the auto energy saving mode will consume less power than ordinary V/F control.

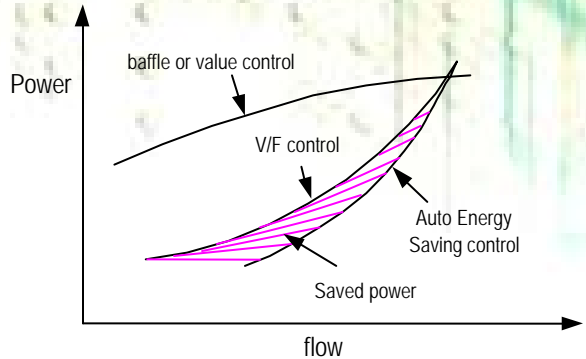

NOISE FILTER

- When input noise filter is installed as indicated, the 7300PA will comply with the EN50081-2 (1994) noise interference suppression directive.

INVERTER	Voltage (V)		440V															
	HP		25	30	40	50	60	75	100	125	150	175	215	250	300	350	400	500
	Rated Current (A)		38	44	59	75	86	111	151	189	231	267	304	340	380	516	585	732
Input Noise Filter	Rated Current (A)		50	50	80	80	120	120	200	200	320	320	320	400	400	600	600	800

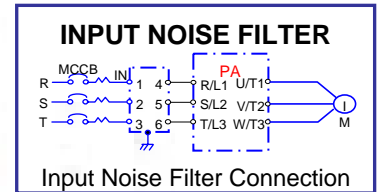

DIGITAL OPERATOR

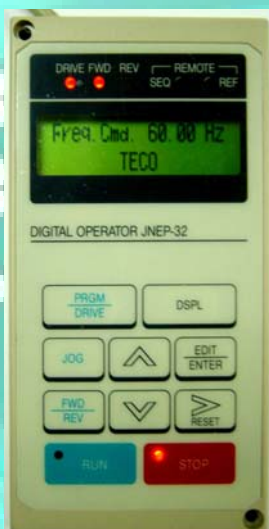

LCD OP

- Use Graphic LCD, Dual language(Chinese& English)
- Key function similar to as existent TECO inverter
- LCD operator · Memory built in, used us Copy unit

LED OP

- Big size LED operator(optional)
- Same Installation and Dimension as LCD OP



SPEECON 7300PA

◆ SPECIFICATIONS

230V CLASS

INVERTER (HP)		25	30	40	50	60	75	100	125
MAX. APPLICABLE MOTOR OUTPUT HP (KW) *1		25 (18.5)	30 (22)	40 (30)	50 (37)	60 (45)	75 (55)	100 (75)	125 (90)
Output Characteristics	Inverter Capacity (KVA)	27.4	33	44	55	63	81	110	125
	Rated Output Current (A)	72	88	117	144	167	212	288	327
	Max. Output Frequency	3-Phase, 200/208/220/230V (Proportional to input voltage)							
	Rated Output Frequency	Up to 180Hz available							
Power Supply	Rated Input Voltage And Frequency	3-Phase, 200/208/220V, 50Hz 200/208/220/230V, 60Hz							
	Allowable Voltage Fluctuation	+10% ~ -15%							
	Allowable Frequency Fluctuation	±5%							

460V CLASS

INVERTER (HP)		25	30	40	50	60	75	100	125	150	175	215	250	300	350	400	500
MAX. APPLICABLE MOTOR OUTPUT HP (KW) *1		25 (18.5)	30 (22)	40 (30)	50 (37)	60 (45)	75 (55)	100 (75)	125 (90)	150 (110)	175 (132)	215 (160)	250 (185)	300 (220)	350 (260)	400 (300)	500 (375)
Output Characteristics	Inverter Capacity (KVA)	29	34	45	57	66	85	115	144	176	203	232	259	290	393	446	558
	Rated Output Current (A)	38	44	59	75	86	111	151	189	231	267	304	340	380	516	585	732
	Max. Output Frequency	3-Phase, 380/400/415/440/460V (Proportional to input voltage)															
	Rated Output Frequency	Up to 180Hz available															
Power Supply	Rated Input Voltage And Frequency	3-Phase, 380/400/415/440/460V, 50/60Hz															
	Allowable Voltage Fluctuation	+10% ~ -15%															
	Allowable Frequency Fluctuation	±5%															

* Based on 4 pole motor

* 5~20 HP to be available soon.

SPEECON 7300PA

◆ CHARACTERISTICS

Control Characteristics	Control Method	Sine wave PWM
	Frequency Control Range	0.1 to 180Hz
	Frequency Accuracy	+14 to 104℉ 77 ± 18℉ Digital command: 0.01% -10 to 40℃ Analog command: 0.1% 25 ± 10℃
	Frequency Setting Resolution	Digital operator reference: 0.01Hz Analog reference: 0.06Hz/60Hz
	Output Frequency Resolution	0.01Hz (1/30000)
	Overload Capacity	110% rated output current for one minute.
	Frequency Setting Signal	0 to 10VDC (20KΩ), 4~20mA (250Ω)
	Accel/Decel time	0.1 to 6000 sec (independent Accel/Decel time settings)
	Braking Torque	Approximately 20%
	No. of. V/f patterns (Total of 5)	1: For adjustable pattern. 4: For fans and pumps.
Protective Functions	Motor Overload Protection	Electric thermal overload relay
	Instantaneous Overcurrent	Motor coasts to stop at approx. 200% rated current.
	Overload	Motor coasts to stop after 1 minute at 110% rated output current.
	Overvoltage (460V class)	Motor coasts to stop if inverter output voltage exceeds 820VDC.
	Overvoltage (230V class)	Motor coasts to stop if inverter output voltage exceeds 410VDC.
	Undervoltage (460V class)	Motor coasts to stop if inverter output voltage drops to 380VDC or below.
	Undervoltage (230V class)	Motor coasts to stop if inverter output voltage drops to 190VDC or below.
	Momentary Power Loss*1	Motor coasts to stop after momentary power loss lasting over 15ms. (time-setting made before shipment).
	Motor Overheat Protection	Motor PTC thermistor (Active: 1330Ω, Return: 550Ω)
	Input phase Loss	Single phase protection.
	Output phase Loss	Provided by electronic circuit.
	Fin Overheat	Thermostat
	Stall Prevention	Stall prevention at acceleration/deceleration and constant speed operation.
	Ground Fault	Provided by electronic circuit.
	Power Charge Indication	Charge lamp stays ON until bus voltage drops below 50V.
Environmental Conditions	Location	Indoor (Protected from corrosive gases and dust)
	Ambient Temperature	Wall-mounted type: +14 to 104℉ (-10 to +40℃),(not frozen) Open chassis type: +14 to 113℉ (-10 to +45℃), (not frozen)
	Storage Temperature	-4 to 140℉ (-20 to +60℃)
	Humidity	95% RH (non-condensing)
	Vibration	1G at 10 to 20Hz, up to 0.2G at 20 to 50Hz.
Communication Function	RS-485 MODBUS, PROFIBUS (option)	
Noise Interference Suppression	EN 50081-2 (1994) with specified noise filter	
Noise Immunity	Pr EN50082-2	

SPEECON 7300PA

◆ MAIN CIRCUIT TERMINALS

TERMINALS	TERMINAL FUNCTION
R / L1	Main Circuit Input Power Supply
S / L2	
T / L3	
U / T1	Inverter Output
V / T2	
W / T3	
⊕	DC Power Supply Input or Braking Unit
⊖	
B2	B2 – ⊕ : External Braking Resistor (Only for 220V 25HP, 440V 25HP, 30HP)
E (PE, $\frac{1}{2}$)	Grounding (3rd Type Grounding)

◆ CONTROL CIRCUIT TERMINALS

I/O	Terminal	Functions	
Digital Input Terminals	1	Forward operation-stop signal.	
	2	Reverse operation-stop signal.	
	3	External fault input.	
	4	Fault reset.	
	5	Multi-function contact input: the following signals available to select. Forward/reverse select, run mode select, multi-speed select, jog frequency select, accel/decel time select, external fault, external coast to stop, hold command, inverter overheat prediction, DB command, aux. Input effective, speed search, energy-saving operation.	
	6		
	7		
	8		
		24VG	SINK Common (0V), ref to appendix D.
		24V	SOURCE Common (24V), ref to appendix D.
		SC	Sequence input Common (24V), ref to appendix D.
	Analog Input Terminals	+15V	+15V power supply for external frequency command.
		VIN	Master speed voltage reference (0 to 10V).
AIN		Master speed current reference (4 to 20mA).	
AUX		Auxiliary analog command: one of the following signals available to select. Frequency command, frequency gain, frequency bias, overtorque detection level, voltage bias, accel/decel rate, DB current.	
MT		Motor temperature PTC thermistor. (active: 1330Ω, Return: 550Ω)	
GND		Analog signal common.	
Digital Output Terminals	E	Connection to shield signal lead. (frame ground)	
	R3A	Fault contact output A (Closed at fault).	
	R3B	Fault contact output B (Open at fault).	
	R3C	Fault contact output common.	
	R2A-R2C	Multi-function contact output: one of the following signals available to output. Output during running, zero speed, synchronized speed, arbitrary speed agreed, frequency detection, overtorque, undervoltage, run mode, coast to stop, braking resistor overheat, alarm, fault.	
	R1A-R1C		
	D01	Multi-function PHC (photo-coupler) output 1 (open collector, 48VDC, 50mA)	The same functions as terminals R1A-R1C and R2A-R2C
DCOM	Multi-function PHC output common.		
Analog Output Terminals	A01	Analog multifunction output port: Frequency command, Output frequency, Output current, Output voltage, DC voltage, Output power.	0~11V max. 2mA or less
	A02		
	GND	Common lead for analog port.	

SPEECON 7300PA

◆ DIMENSIONS

Voltage (V)	Inverter Capacity (HP)	Open Chassis Type (IP00) mm							Weight (Kg)	Enclosed Type (NEMA1) mm						Weight (Kg)	ACL/DCL	Reference Figure
		W	H	D	W1	H1	d	W		H	D	W1	H1	d				
220V	25	265	360	225	245	340	M6	12	265	360	225	245	340	M6	12	External ACL (option)	(a)	
	30	283.5	525	307	220	505	M8	36	291.5	745	307	220	505	M8	38	DCL Built-in (Standard)	(b)	
	40							36							38			
	50							36						38				
	60	344	630	324.5	250	610	M8	47	352	945	324.5	250	610	M8	50	DCL Built-in (Standard)		
	75							49							52			
	100							82							87			
	125	459	790	324.6	320	760	M10	82	462	1105	324.6	320	760	M10	87			
440V	25	265	360	225	245	340	M6	12	265	360	225	245	340	M6	12	External ACL (option)		(a)
	30							12							12			
	40	283.5	525	307	220	505	M8	36	291.5	745	307	220	505	M8	38	DCL Built-in (Standard)	(b)	
	50							36							38			
	60							47							50	DCL Built-in (Standard)		
	75	344	630	324.5	250	610	M8	47	352	945	324.5	250	610	M8	50			
	100							47							50			
	125							80							85	DCL Built-in (Standard)		
	150	459	790	324.6	320	760	M10	80	462	1105	324.6	320	760	M10	85			
	175							81							86			
	215							128							135	DCL Built-in (Standard)		
	250	599	1000	381.6	460	960	M12	128	602	1305	381.6	460	960	M12	135			
	300							132							139			
	350							160							166	External ACL (option)		
	400	730	1230	382	690	930	M12	170	730	1330	382	690	930	M12	176			
500							190							196				

(a) 220V: 25HP
440V: 25HP, 30HP

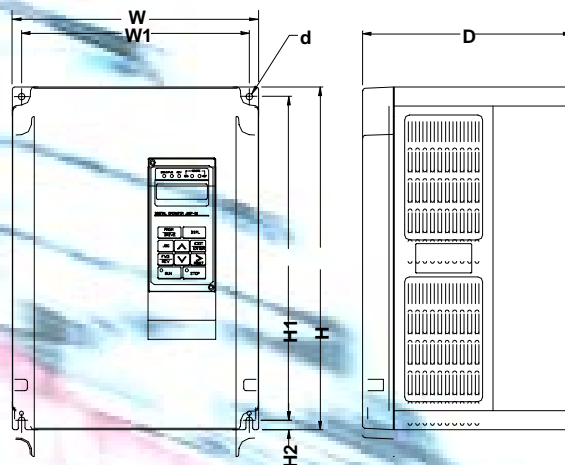

SPEECON 7300PA

(b) 220V: 30HP~125HP
440V: 40HP~300HP

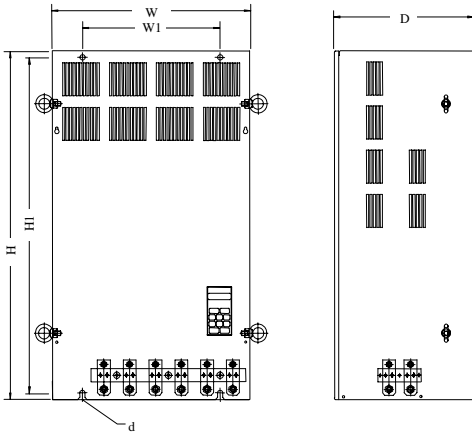

(Open Chassis Type – IP00)

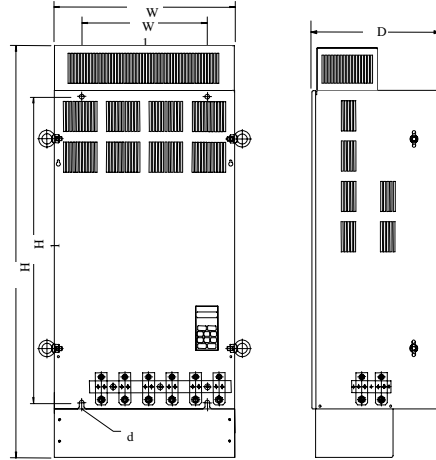

(Wall-mounted Type – NEMA1)

(c) 440V: 350HP

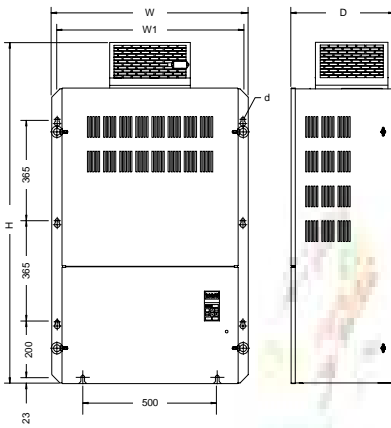

(Open Chassis Type – IP00)

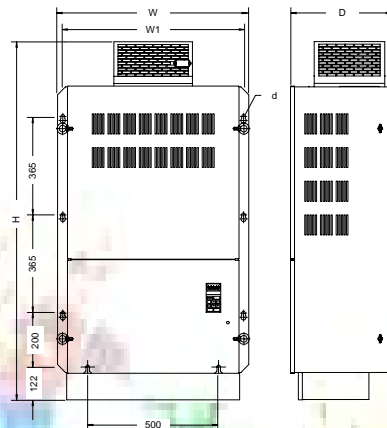

(Wall-mounted Type – NEMA1)

(d) 440V: 440HP, 500HP

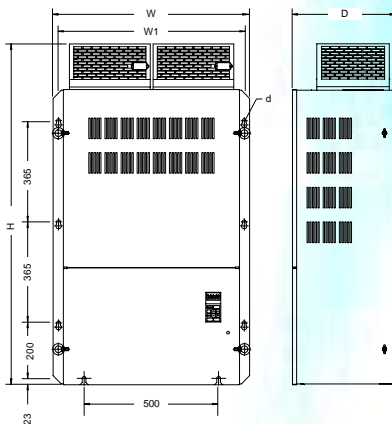

(Open Chassis Type – IP00)

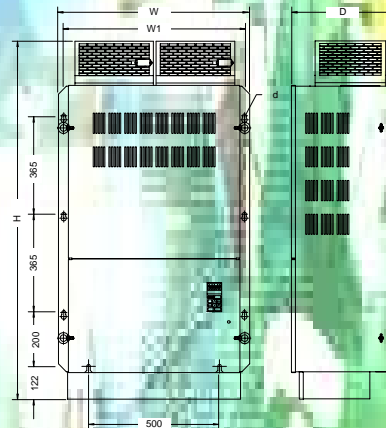

(Wall-mounted Type – NEMA1)

SPEECON 7300PA

◆ CONNECTION DIAGRAM

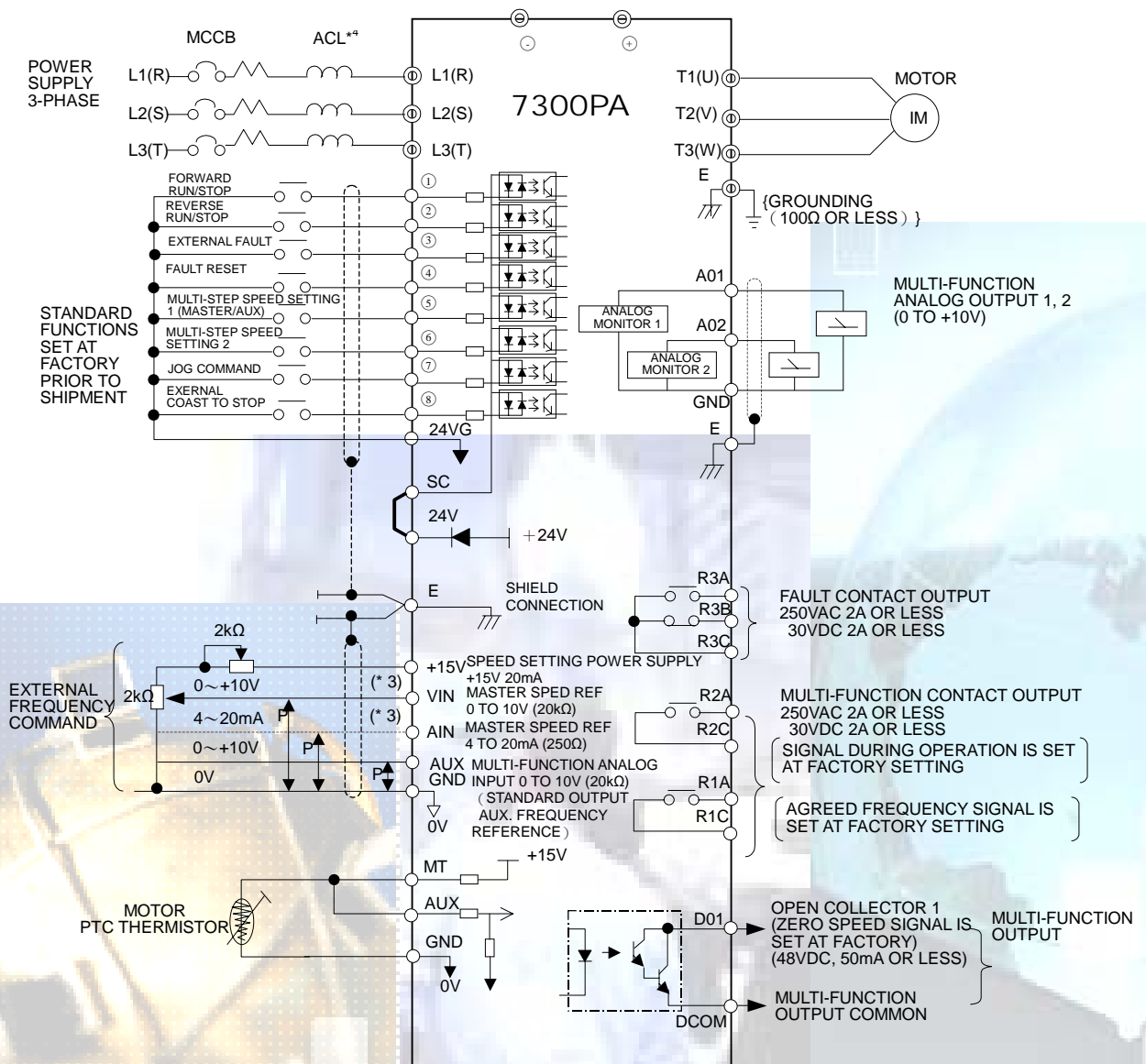

* 1. shield wire shield twisted wire

* 2. The terminal ① ~ ⑧ can be connected as SINK or SOURCE type input interface.
(Ref. to Appendix D)

* 3. The terminal arrangement.

1	2	3	4	5	6	7	8	9	10	11	12	13	14	15	16	17	18	19	20	21	22	23	24	1	2	3	4	5	6	7
24VG	24VG	1	2	3	4	5	6	7	8	SC	24V	E	15V	VIN	AIN	AUX	MT	GND	A01	A02	GND	D01	DCOM	R1A	R1C	R2A	R2C	R3A	R3B	R3C

*
Shorted at factory

* 4. External ACL is a must for 350HP ~ 500HP (DCL built-in for 40HP ~ 300HP).

AMERICA

TECO-Westinghouse Motor Co.
PO Box 227 (78680-0277)
N-1H35 at Westinghouse Rd
Round Rock, Texas 78681, USA
TEL: +1 512 255 4141
FAX: +1 512 244 5500
<http://www.tecowestinghouse.com>

CANADA

TECO-Westinghouse Motors (Canada)
Inc., 18060-109 Avenue, Edmonton,
Alberta Y5S 2K2, Canada
TEL: +1 780 444 8933
FAX: +1 780 486 4575
<http://www.twmi.com>

UNITED KINGDOM

TECO Electric Europe Limited.
Teco Building, Marshall Stevens Way,
Trafford Park, Manchester
M17 1PP, England, United Kingdom
TEL: +44 (0)161 877 8025
FAX: +44 (0)161 877 8030
Email: enquiries@teco.co.uk

GERMANY

TECO-Westinghouse, Niederlassung
Deutschland, Peiner Strasse 31,
31319 Sehnde
TEL: +49 (0) 5138 7087997
FAX: +49 (0) 5138 7087998
Email: teco.germany@t-online.de

AUSTRALIA

TECO Australia Pty Ltd
335-337 Woodpark Road,
Smithfield, NSW 2164, Australia
TEL: +61 2 29765 8118
FAX: +61 2 29604 9330
<http://www.teco.com.au>

CHINA

WUXI Teco Electric & Machinery Co. Ltd.,
No.72 Wuxi National Hi-Tech.
Industrial Development Zone,
New District, Jiang Su, China
TEL: +86 510 5342005~7
FAX: +86 510 5342053

JAPAN

SANKYO Co. Ltd, Rm 301, 9th R
Shinhamamatsucho Bldg, 1-27-9
Hamamatsucho, Shiba-daimon,
Minato Ku, Tokyo, Japan
TEL: +81 3 3435 7818
FAX: +81 3 3578 8381

THAILAND

TECO Electric & Machinery (Thai)
Co. Ltd., 128/1 Soi Watsrivarenoi,
Moo 7, Bangna-Trad Rd, KM 18,
Bangchalong, Bangplee,
Samuthprakarn 10540, Thailand
TEL: +662 3371311-20
FAX: +662 3371630
Email: teco01@asianet.co.th
<http://teco.co.th>

SINGAPORE

TECO Electric & Machinery (PTE) Ltd
18 Chin Bee Drive, Singapore 619865
TEL: +65 6265 4632
FAX: +65 6265 7354
<http://www.teco.com.sg>

MALAYSIA

STE Technology Sdn. Bhd.
No. 10, Jalan BP 4/4,
Bandar Bukit Puchong,
47100 Puchong, Selangor, Malaysia
TEL: +60 (3) 8068 1232
FAX: +60 (3) 8068 1239
Email: tecoste@tm.net.my
<http://www.ste-tech.com.my>

INDONESIA

PT. TECO Multiguna Elektro
JL. Bandengan Utara, No. 83/1-2-3
Jarkata Utara-14440, Indonesia
TEL: +62 21 6626065
FAX: +62 21 6626066
Email: tecoindo@teco.co.id

HONG KONG

TECOSON Industrial, Development
(HK) Co Ltd, Rm 3504-07 Hong Kong
Plaza, 186-191 Connaught Rd
West, Hong Kong
TEL: +852 2858 3220
FAX: +852 2540 4592



TECO ELECTRIC & MACHINERY CO., LTD.

49, WU KUNG 6 RD., WU KU INDUSTRIAL DISTRICT, TAIPEI HSIANG, TAIWAN

TEL: 886-2-89901111 FAX: 886-2-22900465 HTTP://www.teco.com.tw